

DSG Clutch Basket Circlip Selecting

1. Using a veneer caliper, locate and install the 2mm circlip onto the input shaft (arrow).

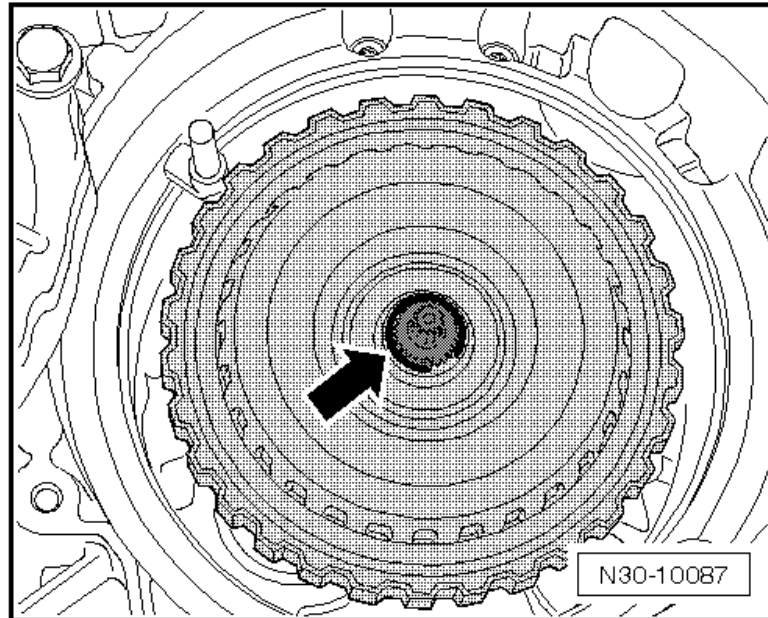

2. Attach the dial indicator holder (VW Special Tool - VW 387) to the transmission flange. For the 1st measurement, place dial gauge measuring tip on input shaft, as show in the illustration. Set the dial gauge with 2 mm preload to "0". Raise the multi-plate clutch all the way up. Read and record the measurement (input shaft axial play).

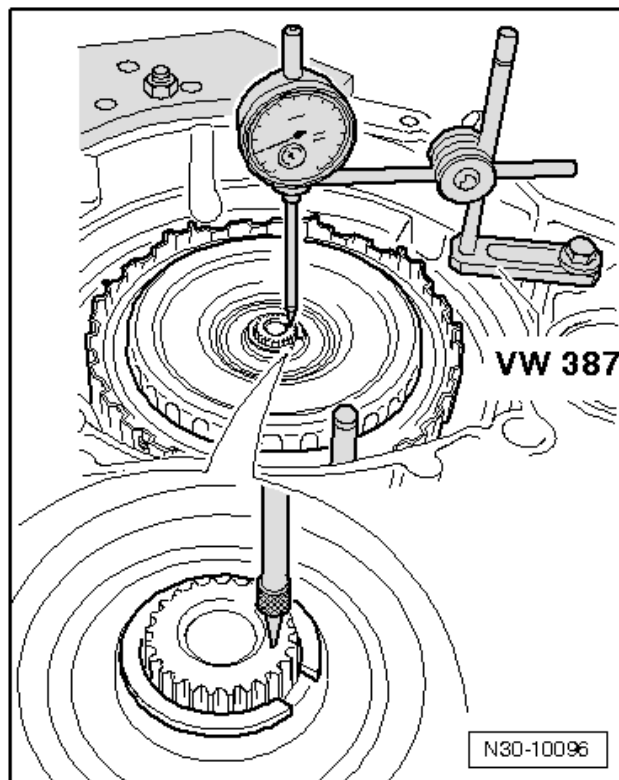

3. For the 2nd measurement, place dial gauge measuring tip on inner clutch pack carrier hub, as show in the illustration. NOTE: Measuring tip must not be placed on circlip. Set the dial gauge with 2 mm preload to "0". Raise the multi-plate clutch all the way up. Read and record the measurement. The new circlip will be determined using the following formula:

Circlip = 2nd Measurement – 1st Measurement + 1.85 (constant value)

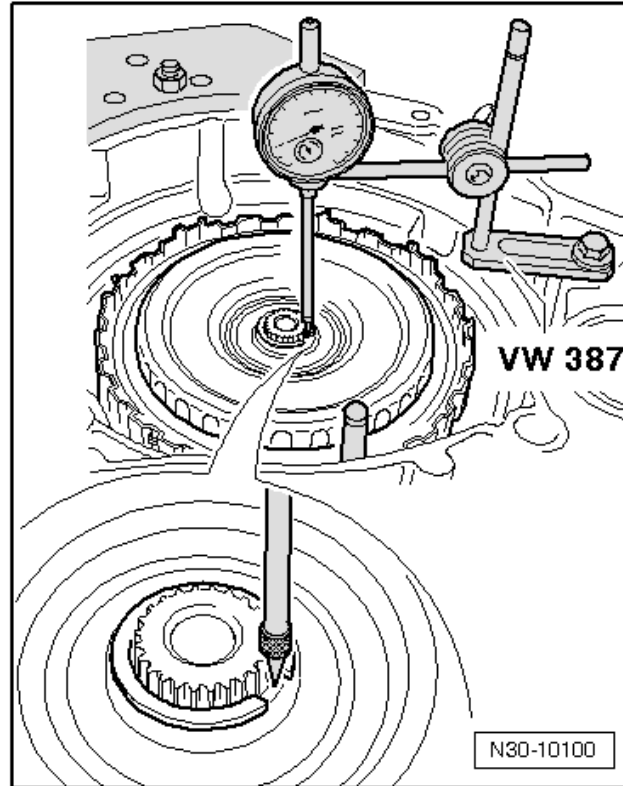

4. The new circlips are staggered in 0.1 mm increments. Round to the closest number when selecting: Up to 0.049 is rounded down, and from 0.05 on is rounded up. Remove the 2mm circlip and install the proper one. If it is determined that the proper circlip should be 2mm, leave the 2mm installed.

